



AP-5CR288FE0AU Integrated Fridge

Features & Benefits

Design

- Sliding hinge
- Door hinge on right, changeable
- LED interior light

Convenience and safety

- LED electronic control
- 1 Compressor /1 independent cooling system

Refrigerator compartment

- Capacity 180L
- 4 safety glass shelves, of which 3 are height adjustable
- Transparent vario tray for fruit and vegetable
- 4 full-width door shelves
- 1 Bottle tray
- Egg tray

Freezer compartment

- Capacity 63L
- No frost
- Freezing capacity: 3.3kg in 24 hours
- Storage time in case of malfunction: 8 hours
- 3 freezer produce drawers

Specification

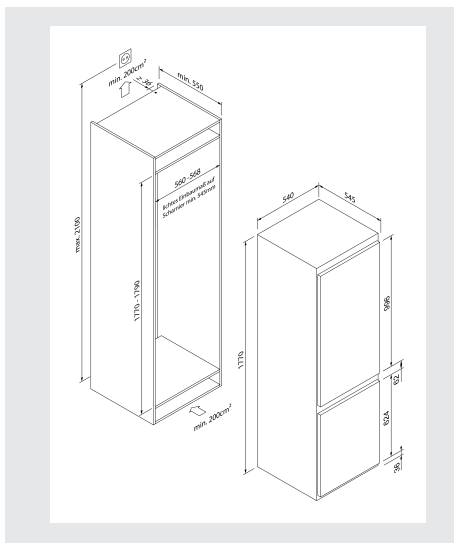

Dimensions

Appliance:
H1770x W540x P545mm

Equipment Feature

- Frost free system
- Interior ventilator
- Reversible Door Hinge
- Fast freezing
- Humidity Control Drawer

Weight

Net: 53kg
Gross: 56.5kg

Net Capacity

243 L

Efficiency Rating

Energy Efficiency
Class: E

Type

Fully integrated

Consumption

- Energy Efficiency Class: E
- Net capacity 243 l
- Net fridge capacity total: 180 l
- Net capacity freezer 63 l
- Energy consumption: 218 kWh/a
- Climate class: N-T
- Super Freezing: No
- Freezing capacity: 3.3 kg / 24h
- Storage time in power failure 8 h
- Noise level: C / 41 dB

Accessories

